



## OPEN-MID RAIL INSTALLATION

### Standard Open Mid-Rail System

**Each Panel Requires:**

- 36" X 6' Panel Kit
- One additional Bottom Snap
- One unpunched H-Channel
- Rail Attach Kit (one kit for two panels)
- 6 Deck Rail Clips per bay

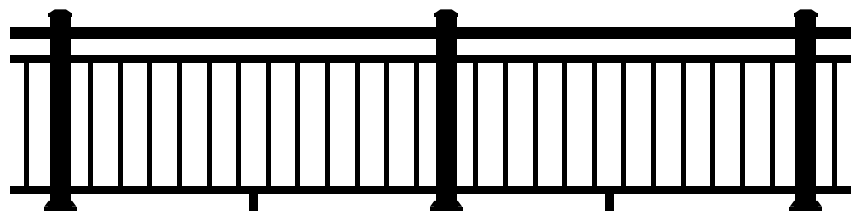

### Continuous Top Rail Open Mid-Rail System

**Each Panel Requires:**

- 36" X 6' or 8' Continuous Top Rail Panel Kits
- One additional Bottom Snap
- One unpunched H-Channel
- Rail Attach Kit (one kit for two panels)
- Continuous Top Rail (span up to 18')
- 5 Deck Rail Clips per bay
- One Crossover Bracket

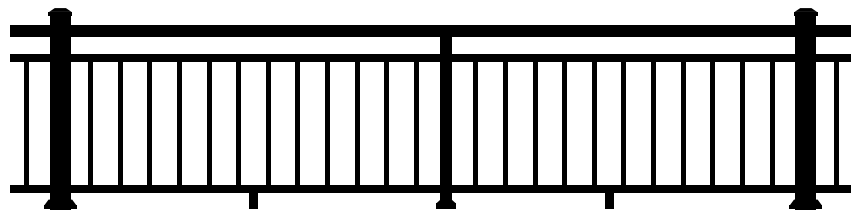

## IMPORTANT NOTE:

**Prior to construction, check with your local regulatory agency for special code requirements in your area.**

Common railing height is 36" or 42". Post spans will vary depending on job site conditions. Never span more than 8' on-center between railing posts. Spans longer than 12' in length will require reduced post spans. When you cut a kit to create two panels, for instance, cutting 8' to two 4', you will need an additional hardware kit. Read instructions completely to get an understanding of how the product goes together and how each piece affects the other.

### \*\*CONCRETE APPLICATIONS\*\*

WHEN POSTS ARE SECURED TO CONCRETE SUBSTRATES USE CONCRETE ANCHORS (SOLD SEPARATELY)

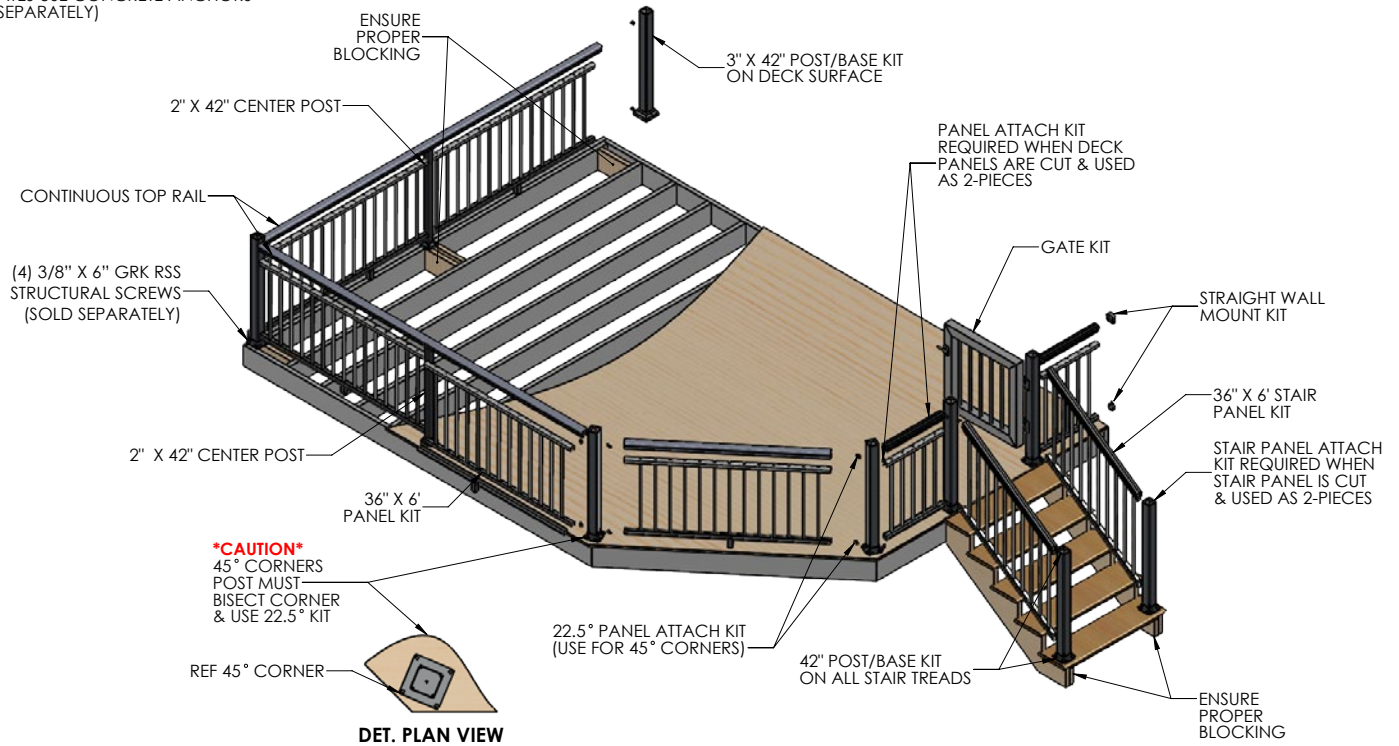

## IMPORTANT NOTE:

42" posts and 36" high railing panels (34" actual size) are required to build 42" high Open Mid-Rail System on a level surface. 48" posts are required for stair applications.

**NOTE: IF INSTALLING POST LIGHTING, WIRING MUST BE INSTALLED PRIOR TO SECURING POSTS TO DECK/STAIR SURFACE AND INSTALLING TOP RAIL SNAPS.**

It is the responsibility of the installer to meet all local code requirements and obtain all required building permits. The installer should determine and implement appropriate installation techniques for each installation situation. UltraLox Interlocking™ or its reseller shall not be held responsible for improper or unsafe installations.

## SUGGESTED TOOLS:

- Appropriate fasteners for mounting posts to deck
- Miter saw with carbide-tipped non-ferrous blade
- Cordless drill
- Tape measure
- Level
- Power cords, drop sheets and safety glasses
- 3/16" Drill bit
- 6" #2 Square drive bit
- Installation jig (optional)

## IMPORTANT NOTE:

**Actual Level Panel Lengths Are As Follows:**

- 6' Panels = 69.43"
- 8' Panels = 91.31"
- 3" posts are required to reach 6' & 8' lengths

# ALUMINUM POST INSTALLATION

## STEP ONE - Determine All Posts Needed and Prepare (end, center or corner)

### IMPORTANT NOTE:

3" posts are required to reach 6' and 8' lengths. 2" posts must be set in-line to panel. **Do not install post caps and vinyl post base covers until railing assembly is completed.**

### Install Lower Deck Rail Clips – Two Options:

#### Option A - When No Installation Jig Is Available

- Measure 2 7/8" from top of casting shoulder and place a pencil mark for location of the top edge of the rail clip. (Dia. #1)
- Center clip on post and secure with (2) - #8x3/4" self-drilling screws. Clips are included in the Panel Kits.

#### Option B - Using Installation Jig (Sold separately. Accessory pack includes Installation Jig and Touch-up paint.)

- Place Installation Jig (w/arrow facing base plate) on top of base plate upper edge. (Dia. #2)
- Place clip in hole and fasten with (2) - #8x3/4" self-drilling screws. Clips are included in the Panel Kits.

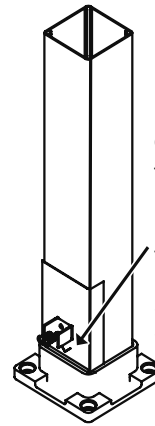
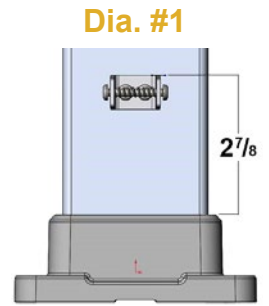

**Dia. #2**

Rest Installation Jig on Base Plate – Arrow Down

Place Clip in hole, hold clip firmly while installing (2) Self-Drilling Screws.

### POST-TO-SURFACE MOUNTING SCREWS:

3" Posts – Residential Deck Applications – 5/16" X 6" Exterior Torx/Star Drive Construction Screws

3" Posts – Commercial Deck Applications – 3/8" X 6" Exterior Torx/Star Drive Construction Screws

2" Posts – Res. & Com. Deck Applications – 3/8" x 6" Exterior Torx/Star Drive Construction Screws

3" Posts – Residential Concrete Applications – Tapcon® 5/16" x 3" Hex Washer Head Concrete Anchor

## STEP TWO - Secure 3" Posts to Deck

- Install proper post blocking (Dia. #3A & 3B). Use proper attachment screws or anchors shown in diagram. (Hardware for post attachment are not provided with the posts.)
- With 3/16" drill bit, pre-drill through deck boards and into blocking. (Dia. #3C)
- Drill a 5/8" hole in center of four deck screw holes for lighting wires (optional).
- Level and plumb post using shims.
- Secure posts to deck frame with suggested screws. (Dia. #3B)
- \*Verify local code requirements for post attachment hardware.
- Install post caps (after panels are installed). (Dia. #4)

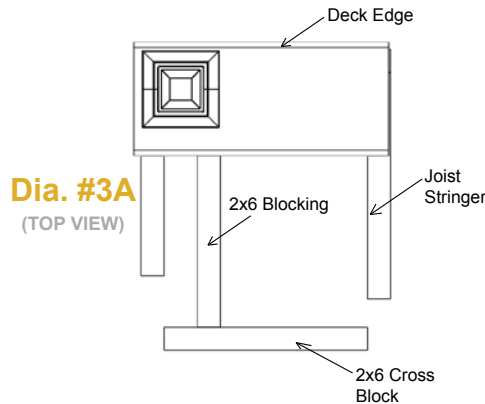

**Dia. #3A**  
(TOP VIEW)

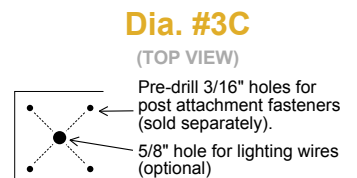

**Dia. #3C**

(TOP VIEW)

Pre-drill 3/16" holes for post attachment fasteners (sold separately).  
5/8" hole for lighting wires (optional)

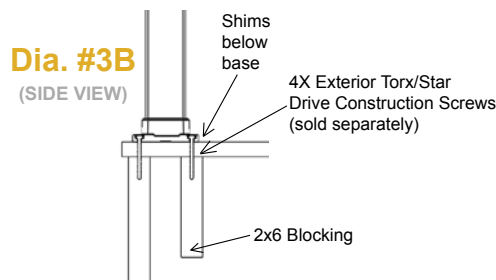

**Dia. #3B**  
(SIDE VIEW)

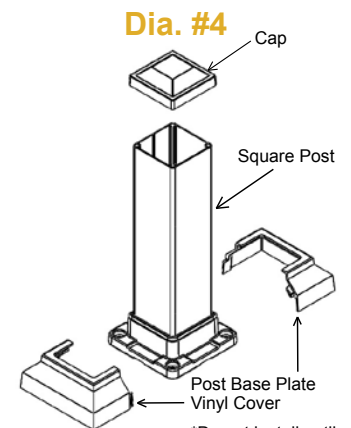

**Dia. #4**

\*Do not install until railing assembly is completed.

## STEP THREE - Install Stair End Posts (if applicable)

- Temporarily install end stair post so rail centerline aligns with top stair posts installed in Step 1 (if applicable). Recommended post installation locations are shown. (Dia. #5) Confirm with local code officials before installing stair rail sections or stair rail posts to ensure compliance with local code requirements.

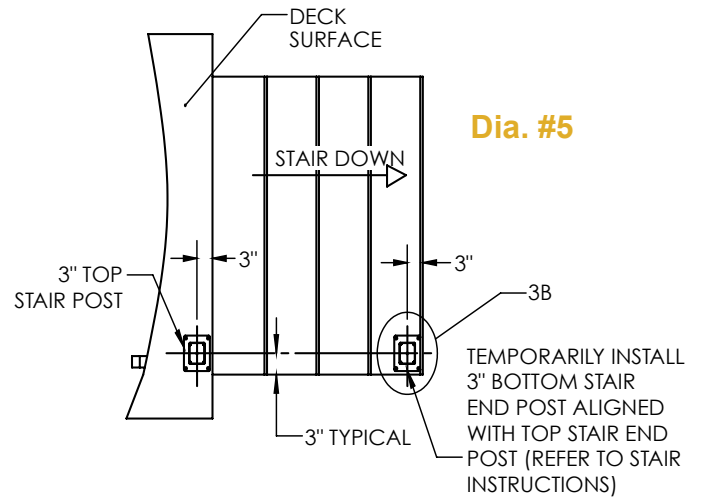

## STEP FOUR - Install End Posts (if applicable)

Install posts at all end locations with maximum gap between post and wall to be less than a 4" opening. (Dia. #6)

**IMPORTANT NOTE:**  
3" posts are required at all transitions. 2" posts may not be used to start/end a run or to form a corner.

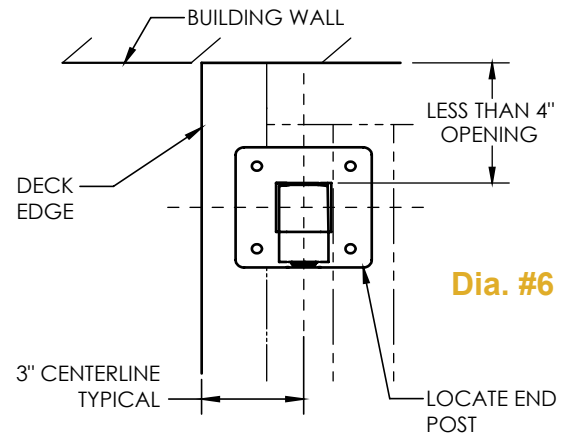

## STEP FIVE - Install 90-degree Corner Posts

Position post on same 3" centerline (typical) and temporarily fasten using a single fastener through base plate mounting hole. (Dia. #7)

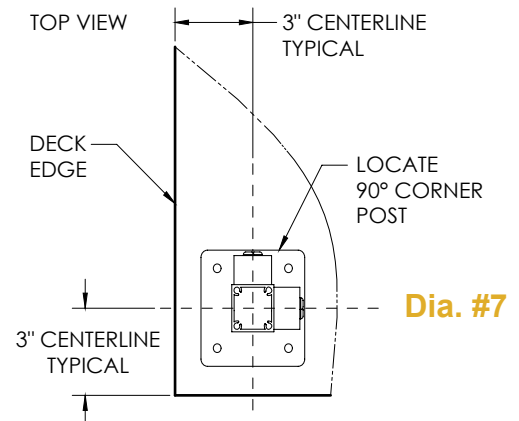

## STEP SIX - Install 45° Corner Posts

(Post to be installed at 22.5° to accommodate a 45° angle.)

Position post on same 3" centerline (typical) and temporarily fasten to deck surface. Use one 22.5° Panel Attach Kit (purchased separately) to install 45 degree corner posts. (Dia. #8)

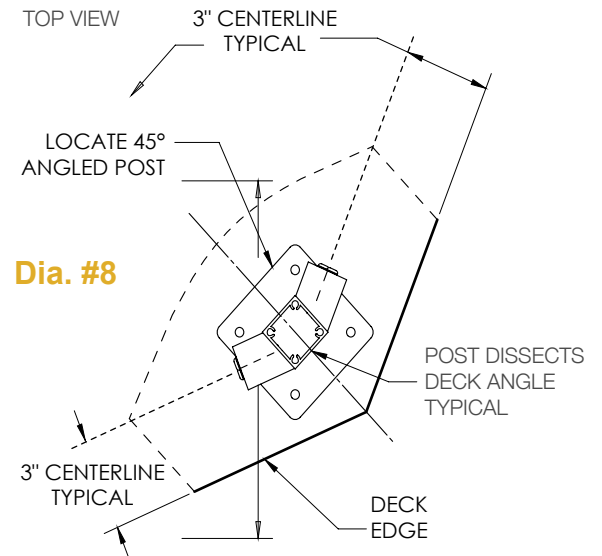

## STEP SEVEN - Determine Center Post Locations

Loosely lay center post over deck edge and adjust as required to determine final center post mounting locations. (Dia. #9 & #10)

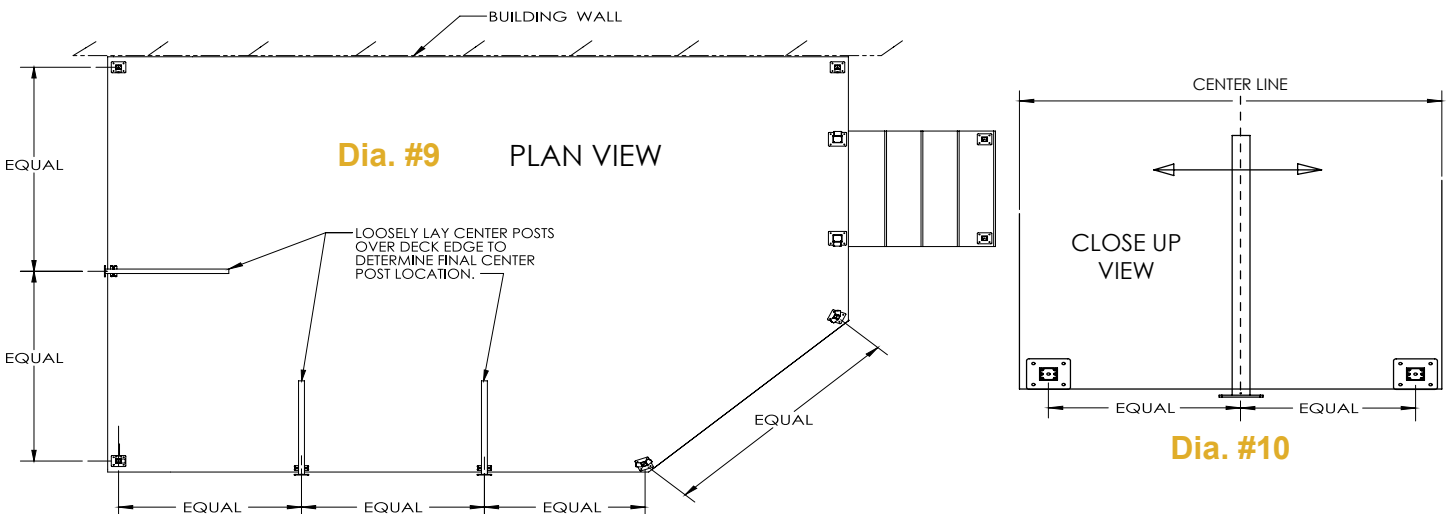

## STEP EIGHT - Secure 2" Posts to Deck (center only)

- For continuous top rail systems, install 2" posts centered between 3" end and corner posts.

**NOTE: 2" Posts must be installed with center screw chases in-line with panel (Dia. #11).**

- Follow instructions in step 2 (Dia. #3A to Dia. #4).

### IMPORTANT NOTE:

3" posts are required at all transitions. 2" posts may not be used to start/end a run or to form a corner.

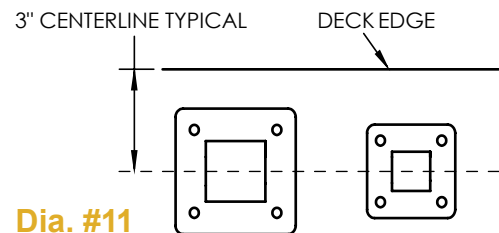

## STEP NINE - Install Crossover Brackets on 2" Posts

- With 6" #2 square drive bit, fasten straight crossover bracket (included) into post with (2) - #8x1.5" Self-Drilling Screws. (Dia. #12A & #12B)

**NOTE: Self-Drilling Screws must be installed in screw chases in-line with panels.**

- With 6" #2 square drive bit, fasten H-channel to straight and stair crossover brackets with (4) - #8x3/4" Self-Drilling Screws. (Dia. #12C & #12D) Repeat for lower clips.
- Install base plate vinyl cover only after railing assembly is completed. (Dia. #4)

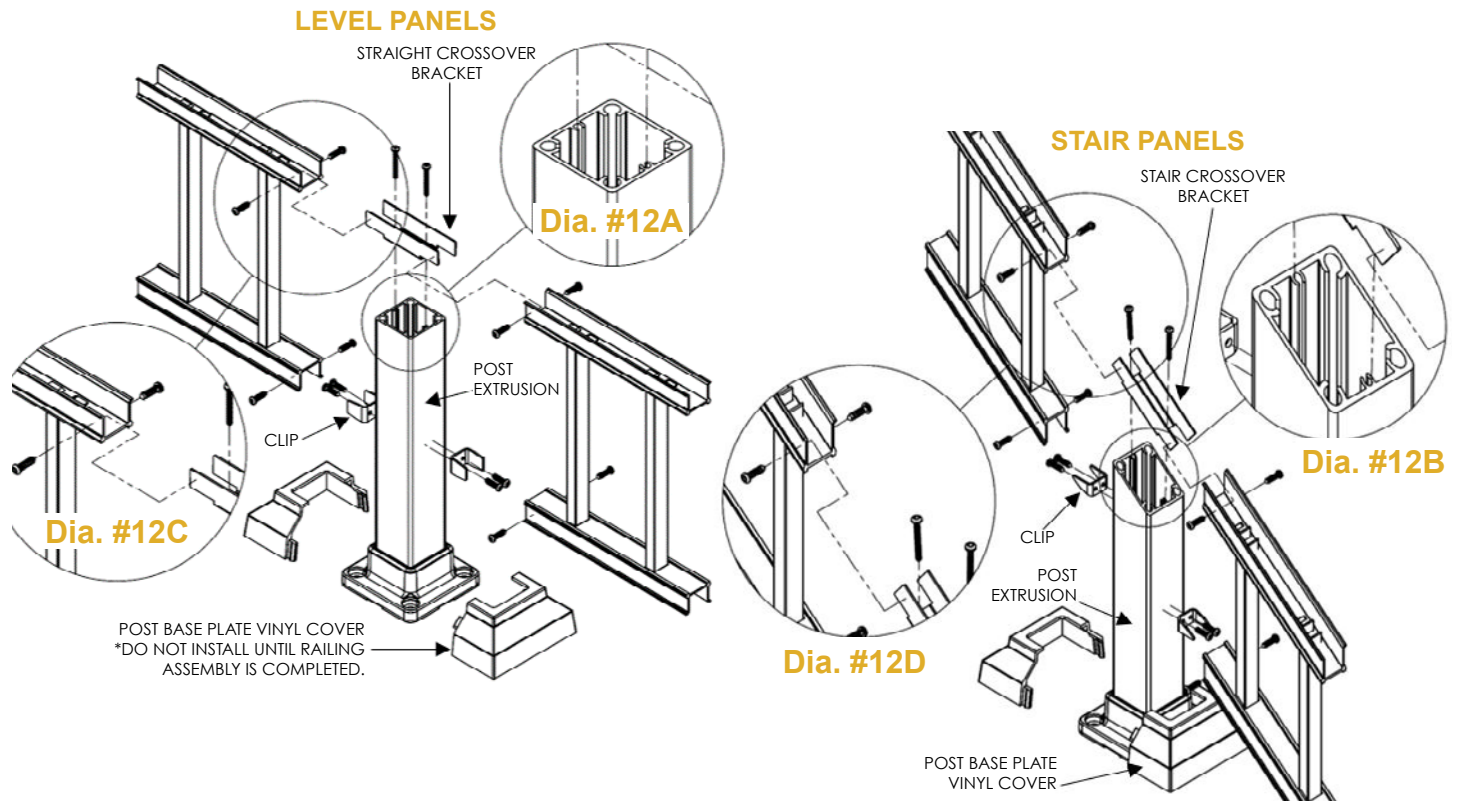

# DECK PANEL INSTALLATION

## STEP ONE - Cut Level Panels and H-channels

Clamp or hold panel against post, adjust for equal end spacing. (Dia. #1)

- Determine the desired center of the rail; either a baluster hole or between two baluster holes. (Dia. #1A)
- Measuring from the determined center, cut both ends of the rails.
- Mark the top and bottom rails and H-channel.
- Cut panel and H-channel 1/16" less than opening size.
- Clean cut areas and apply touch-up paint on exposed ends. Touch-up paint sold separately.

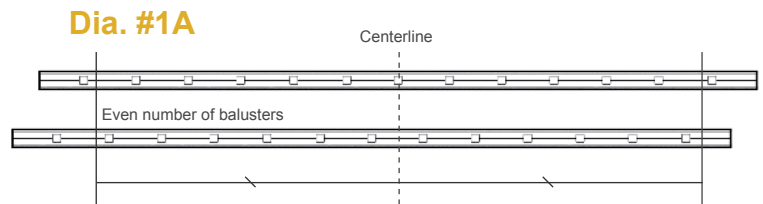
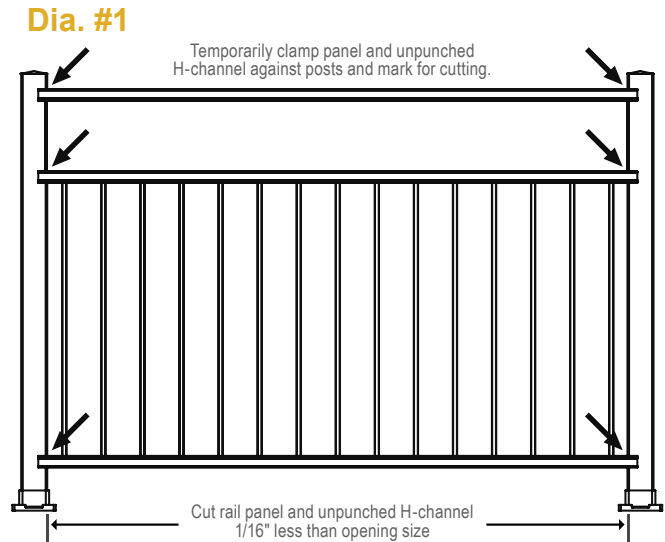

## STEP TWO - Secure Level Panels to Posts

Slide bottom H-channel of pre-cut panel on to lower clip. (Dia. #2)

- Insert clips into top H-channel of panel on each end.
- Using (4) - #8x3/4" self-drilling screws, attach the upper 2-clips to the post.
- Using (8) - #8x3/4" self-drilling screws, secure the upper and lower clips to the panel.
- **Tip:** Use a 6" drill bit for easier installation of top attachment clip to post.

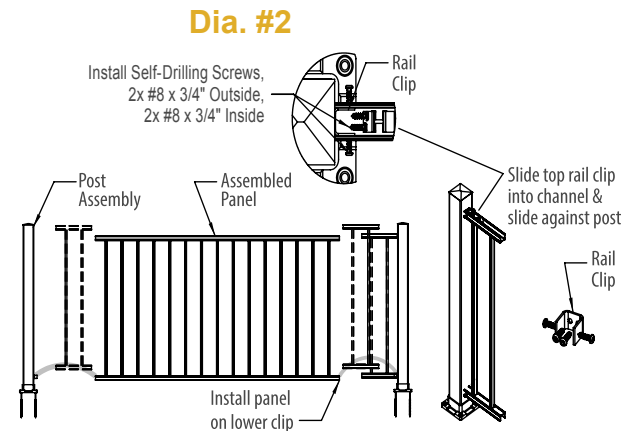

## STEP THREE - Cut and Install Two Bottom Rail Snaps

- Measure between posts at the top and bottom. (Dia.#3)
- For Continuous Top Rail, measure opening from 3" post to 3" post.
- Cut two bottom snap covers 1/16" less than opening(s).
- Clean cut areas and apply touch-up paint on all exposed metal.
- Snap two bottom rail snaps over the rail channels until properly seated. (Dia. #4)

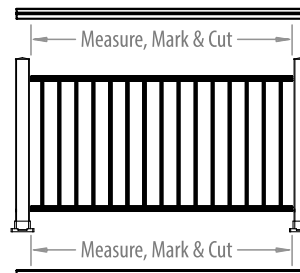

Dia. #3

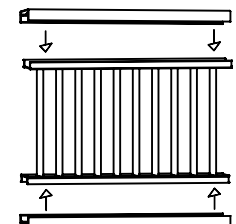

Dia. #4

**NOTE: Do not install top snaps yet.**

## STEP FOUR - Secure Unpunched H-Channels to Posts

- Measure and mark 3 7/8" above upper bottom snap. (Dia. #5)  
For Continuous Top Rail System, use crossover brackets on 2" posts. (Page 7, Dia. #11)
- Using (4) - #8x3/4" self-drilling screws, attach the upper 2 clips to the post. (Dia. #6)
- Using (4) - #8x3/4" self-drilling screws, secure the upper clips to the unpunched H-channel. (Dia. #7)

**NOTE: Do not install top snaps yet.**

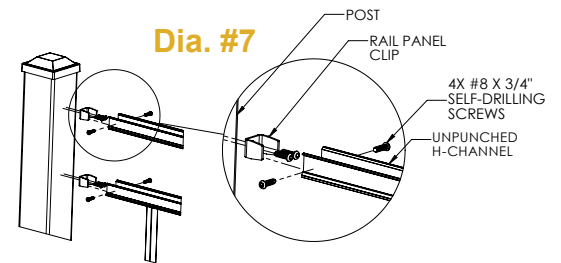
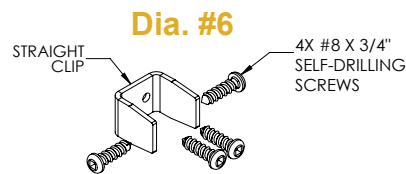
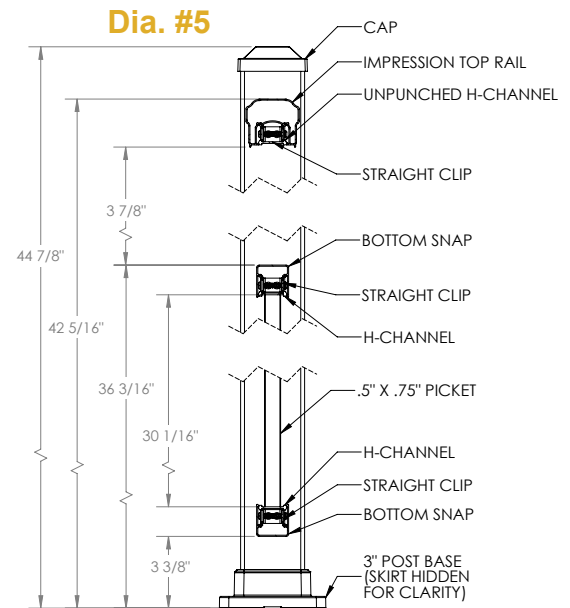

## STEP FIVE - Install Support Legs

For openings greater than 4', install Support Legs under center of bottom rail (Dia. #8)

- Slide Support Leg under bottom rail and mark.
- Install two deck screws at location of Support Leg, install Support Leg over screws.
- Using (1) - #8x3/4" self drilling screw, secure the Support Leg to bottom rail, from the outside of the panel so the screw will not be visible from the deck surface. (Dia. #9)

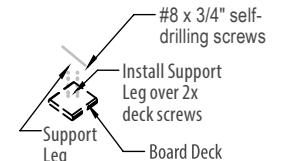
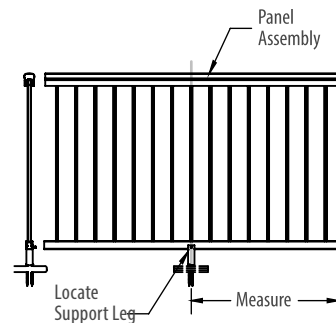

Dia. #8

Dia. #9



## IMPORTANT NOTE:

The top snap covers should snap firmly onto the aluminum railing channels. **Do not use a hammer.** The top rails will snap by applying pressure from one end to the other. If you're having issues snapping on the covers, check the clips to ensure that they are bottomed out into the aluminum railing channels. **Support Legs must be installed BEFORE installing Top Rail Snaps.**

## STEP SIX - Install Top Rail Snaps

- Snap top rail snap over the unpunched H-channel until properly seated. (Dia. #10) **TIP:** Roll the Top Rail Snap in place to avoid scratching the posts and put weight down to get to the "second" snap.

**NOTE:** Do not install top snaps yet if lighting wires will be run through top rails.

Dia. #10



## STEP SEVEN - Wall Mounts (optional)

Use Wall Mounts if attaching level railing panels to structural surfaces instead of posts.

- One Top Rail Wall Mount and two Bottom Rail Wall Mounts are required to attach one Open Mid-Rail panel to a structural surface. (Dia. #11)
- Measure and mark locations on structural surface for placement of three wall mounts. (Dia. #5 & #12)
- Attach wall mounts to structural surface.

**NOTE:** Wall mounting screws are dependent on the type of structural surface. Consult a professional if unsure of proper mounting screws.

- Continue installation of rail panels

Dia. #11

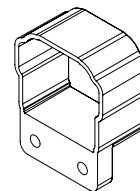

(1X) TOP RAIL WALL MOUNT

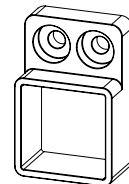

(2X) BOTTOM RAIL WALL MOUNT

Dia. #12

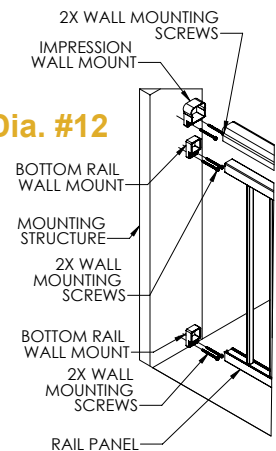

# STAIR PANEL INSTALLATION

## IMPORTANT NOTES:

- Actual Stair Panel Lengths: 6' Panels = 69.43" and 8' Panels = 91.31". 3" posts are required to reach 6' and 8' lengths.
- Stair railing panels are shipped at a 37 degree angle. Panels are adjustable +/- 3 degrees.
- Maximum post spans on stair railing application is 96" on center. Additional posts are required on any stair application more than 8' in length.
- For all other applications, consult a design professional or an Impression Rail® Express representative for more information.

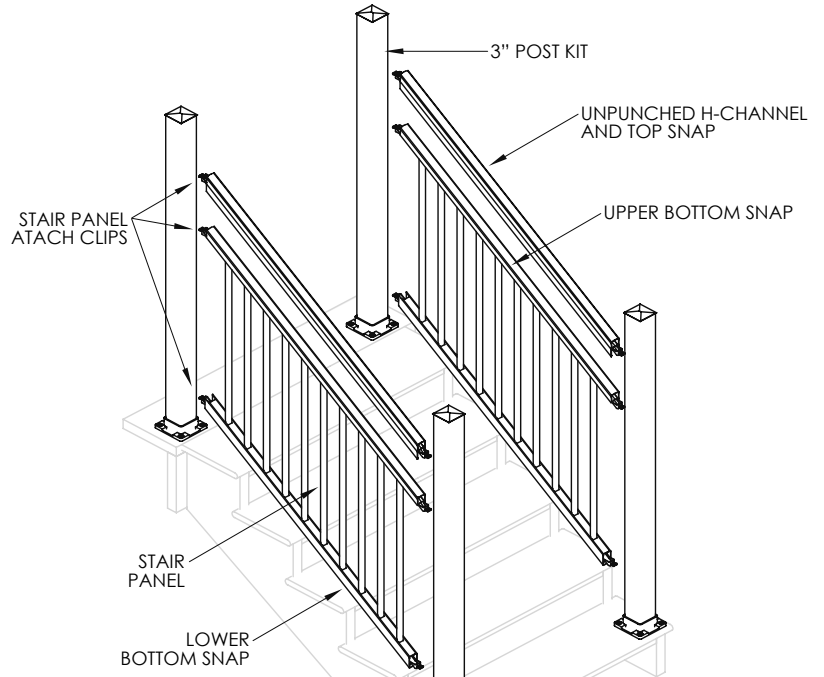

## STEP ONE - Fit Stair Railing Panels

- Position stair railing panel alongside 3" top stair post and temporarily installed 3" bottom post. (Dia. 1A)
- Determine the desired center of the rail: either a baluster hole or between two baluster holes. (Dia. 1C)
- Measuring from the determined center, cut both ends of the rails.
- Position stair panel approximately 1 1/2" above stair nosing. **Tip: lay a 2x4" board flat on nose of stair treads. This will allow enough room for installation of bottom snap.** Clamp stair panel against top and bottom 3" posts. Using a sharp #2 pencil, mark the stair channels at four (4) locations.
- If using a continuous top rail, after panel has been clamped to post, mark cut lines on the H-channel and the 2" post using the bottom of the H-channel to find your angle for post cut. (Dia. 1B)
- Remove clamps and cut stair panel at all four (4) locations. (Dia. 2) Take care to cut stair channels at appropriate stair angle. Use of Miter saw with a sharp non-ferrous blade is recommended.
- Clean cut areas and apply touch-up paint on all exposed ends.

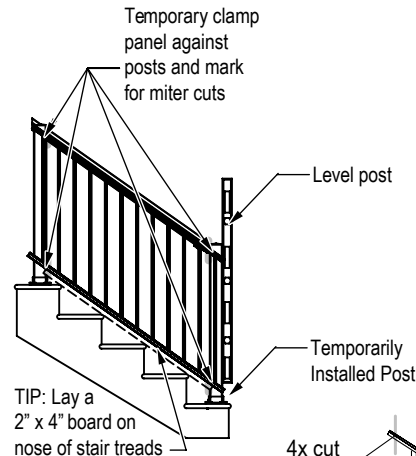

Dia. #1A

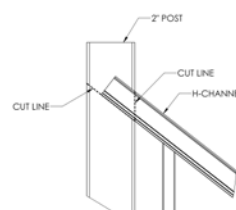

Dia. #1B

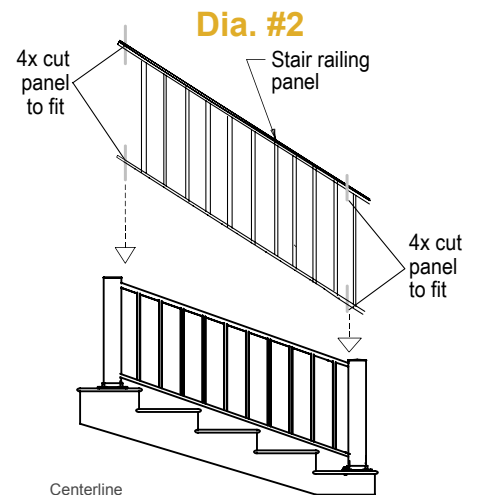

Dia. #2

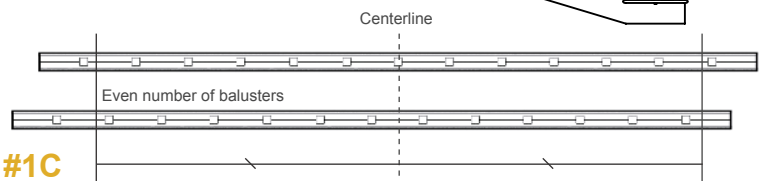

Dia. #1C

## STEP TWO - Install Stair Clips On Posts

- After stair panel has been cut to proper size and angle, place the panel on the 2x4 (or hold 1 1/2" above stair nosing) board, between the 3" posts. Use a #2 sharp pencil to draw a line across the top of the lower H-channel in two places (Dia. 3).
- Remove panel and bottom post. Attach stair panel attach clips at marked location as per (Dia. 4) and fasten with #8x3/4" self-drilling screws.
- **NOTE: Rail clip jigs are not used for stair panel installation.**

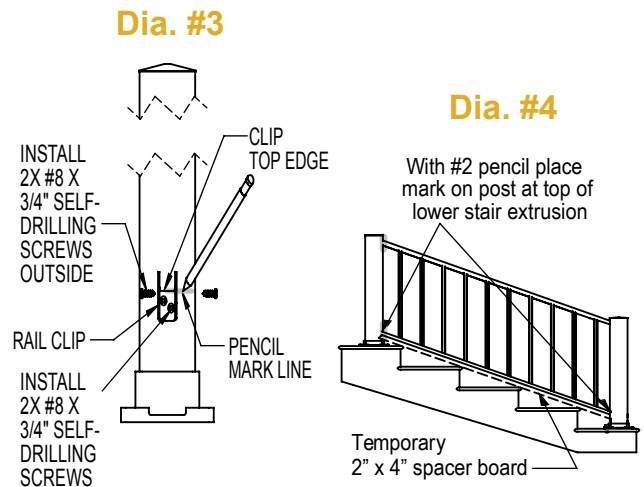

## STEP THREE - Secure Stair Panel To 3" Posts

- Once the stair panel attach clips have been installed, re-attach the lower 3" post to the bottom step or landing. Place the stair panel onto the lower stair panel attach clips (Dia. 5).
- When lower extrusion is fully seated on lower clips, insert stair panel attach clips into upper extrusion. Secure attach clips to post with 2-#8x3/4" self-drilling screws, then secure upper extrusion to stair panel attach clip with 2-#8x3/4" self-drilling screws. Repeat this same procedure for bottom post, upper extrusion (Dia. 6).
- When upper extrusion is secured to attach clips, return to lower extrusion and secure lower extrusion to lower stair clips with 2-#8x3/4" self-drilling screws at upper post and 2-#8x3/4" Self-Drilling Screws at lower post.

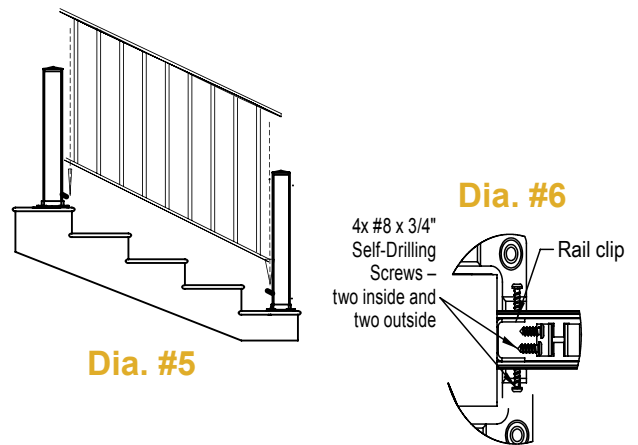

## STEP FOUR - Install Upper and Lower Bottom Snap Covers

- Following the same angle as the secured stair panel, clamp or hold top/bottom rail snaps against 3" posts (Dia. 7). Using a sharp #2 pencil, mark the bottom rail snaps at all four (4) locations.
- Remove clamps and cut bottom rail snaps at all four (4) locations. Take care to cut snaps at appropriate stair angle. Use of Miter saw with a sharp non-ferrous blade is recommended. Cut 1/16" less than opening size.
- Clean cut areas and apply touch-up paint on exposed ends.
- Snap each rail snap over the corresponding rail channel until properly seated (Dia. 8).

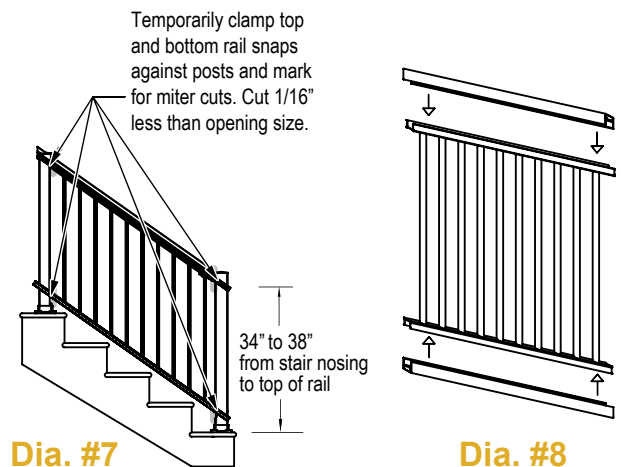

## STEP FIVE - Cut Unpunched H-channels

Clamp or hold panel and H-channel against post, adjust for equal end spacing. (Dia. #9)

- Mark cut lines on the top and bottom rails and H-channel.
- Cut panel and H-channel  $1/16"$  less than opening size.
- Clean cut areas and apply touch-up paint on exposed ends.

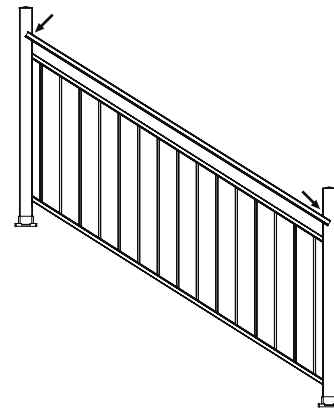

**Dia. #9**

Temporarily clamp unpunched H-channel against posts and mark for cutting.

## STEP SIX - Secure H-channels to Posts

- Measure and mark  $3\ 7/8"$  above upper bottom snap. (Dia. #10)  
For Continuous Top Rail System, use crossover brackets on 2" posts. (Page 7, Dia. #11-12)
- Using (4) - #8x3/4" self-drilling screws, attach the upper 2 clips to the post. (Dia. #11)
- Using (4) - #8x3/4" self-drilling screws, secure the upper clips to the unpunched H-channel. (Dia. #12)
- Snap top rail snap over the unpunched H-channel until properly seated. (Dia. #13)

**NOTE: Do not install top snaps yet if lighting wires will be run through top rails.**

**Dia. #10**

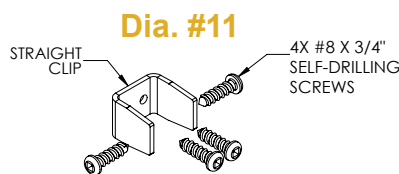
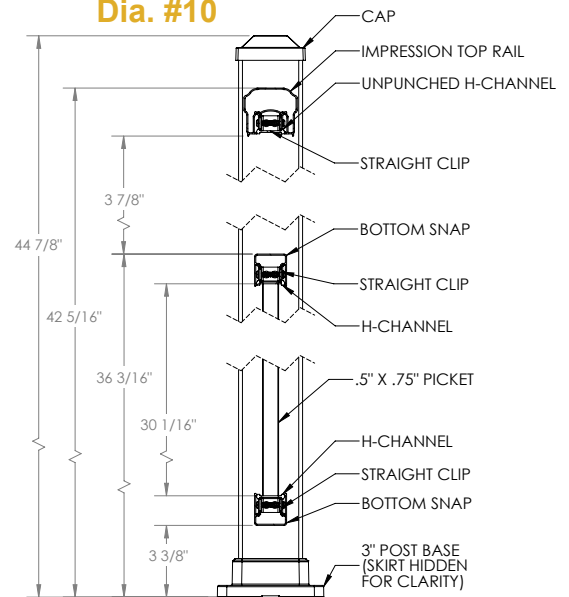

**Dia. #11**

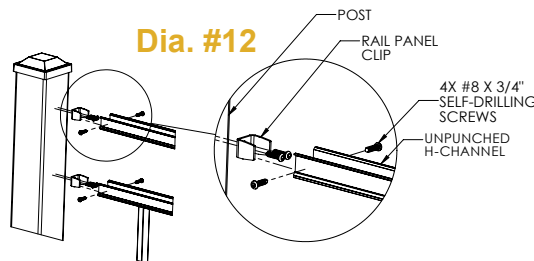

**Dia. #12**

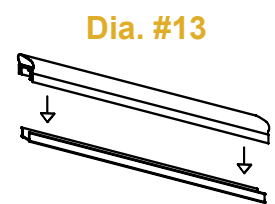

**Dia. #13**

### IMPORTANT NOTE:

It is the responsibility of the installer to meet all local code requirements and obtain all required building permits. The installer should determine and implement appropriate installation techniques for each installation situation. Ultralox Interlocking™ or its reseller shall not be held responsible for improper or unsafe installations.

©2020 Ultralox Interlocking™. All Rights Reserved. Version 1.0